

**SIDE PLANT RESIDUE
SHREDDER – MULCHER
(with hydraulic arm)**

**FPM 618 192 - 1,6 m
FPM 618 193 - 1,8 m
FPM 618 194 - 2,0 m**

№ 63050

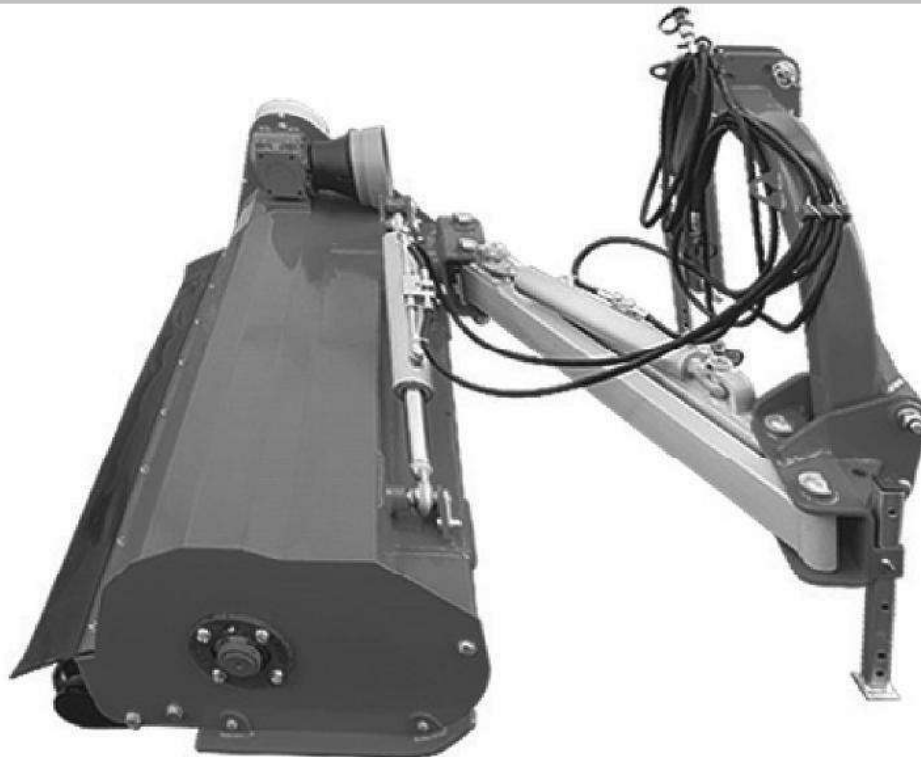

**INSTALLATION / HANDLING / MAINTENANCE
LIST OF SPARE PARTS**



**FPM AGROMEHANIKA AD
Djordja Simeonovica No. 25
Boljevac-Serbia**

- e-mail: info@fpm-agromehanika.rs
- tel. – Sales: + 381 (0)30 463 455; 463 356;
- tel. – Service: + 381 (0)30 463 619
- fax: + 381 (0)30 463 405

SERBIA

<http://www.fpm-agromehanika.rs>

WARNING TO YOU, USER

By purchasing this tool you have made a wise choice. It is the result of many years of thinking, research and improvements. And you will, like thousands of other users, understand that now you possess the best that could be created by technique, knowledge and field testing. You have purchased a reliable tool, but only if you use it correctly, you can expect a good performance and long life.

This Instructions manual provides all the necessary information you need to achieve the best possible efficiency from your tool. The efficiency greatly depends on how carefully you read this Manual and apply this knowledge. This is a simple tool, but one can frequently overlook the obvious deficiencies reflected in the poor performance frequently resulting from the fact that you neglected the natural wear of parts or that the tool has not been set up well. Therefore, do not think that you know how to use and maintain the tool before reading this Manual that you should constantly have at hand.

Our service representatives or sales service centers with its trained staff can offer you all original parts for plant residue shredders - mulchers (for use in orchards and vineyards) and servicing. These parts are manufactured and carefully examined in the same factory where the mulchers are manufactured to ensure high quality and precise fitting for each replacement.

TRACTOR PLANT RESIDUE SHREDDERS – MULCHERS ARE PRODUCED BY: FPM AGROMEHANIKA AD BOLJEVAC

Tractor plant residue shredders meet the criteria stipulated by the Regulation on technical standards for agricultural machinery (Official Gazette of SRJ, No. 34/95) and the Regulation on measures and norms of protection and safety at work equipment (Official Gazette of SFRY No. 18/91) particularly in terms of stability and protection of parts and assemblies that, by their function and form, might threaten the safety of the operator.

IMPROVEMENT: FPM Agromehanika is constantly striving to enhance and improve its products and therefore reserves the right to make changes or improvements as necessary, without any obligation to change previously manufactured or sold equipment.

The information in this Manual is correct as of the date of publishing.

All rights of the press and the images reserved by:
FPM AGROMEHANIKA AD BOLJEVAC

**INTEGRAL PART OF THE INSTRUCTIONS FOR HANDLING AND MAINTENANCE IS THE
CERTIFICATE OF OCCUPATIONAL SAFETY AND DECLARATION OF CONFORMITY 98/37 / EC
WITH THE SAFETY REQUIREMENTS DEFINED BY THE EUROPEAN DIRECTIVES.**



Published by: FPM Agromehanika AD Boljevac
Godina: 2016



CONTENT

Warning to you, user; Personal safety _____	3
Warranty limitations _____	4
Warning labels _____	5
Description of the tool _____	8
Safety _____	9
Specification of the technical characteristics _____	12
Transport of plant residue shredder; Procedure of aggregating on the tractor _____	12
Working with the plant residue shredder _____	14
Helpful tips _____	15
Maintenance _____	18
Certificate (on applied occupational safety measures) _____	21
Declaration of Conformity 98/37/CE _____	22
List of spare part _____	23

WARNING TO YOU, USER

It is very important that the cardan (drive) shaft to be connected to your plant residue shredder – mulcher is of appropriate dimensions.

Therefore it is necessary to provide the cardan shaft of the following characteristics:

- Joint 35 JUS M.L1.601 at the both ends of the cardan shaft
- The shaft is with one-way coupling F5/1R – the right one



IMPORTANT: In case of failure to comply with the above mentioned warning, the factory is not responsible for the damage or breakage on the tractor, the cardan shaft or plant residue shredder – mulcher.

WE WISH YOU A SAFE WORK!

READ CAREFULLY!

In this Manual and on the tools you will find labels with warnings: “CAUTION”; “ATTENTION” and “DANGER”.

Warnings are intended to draw your attention to the personal caution and caution of those who work with you because they need to read them, too.

PERSONAL SAFETY

CAUTION: The word “CAUTION is used where it is necessary to be cautious to protect the operator and others from accident.

ATTENTION: The word “ATTENTION” indicates the possibility of serious injury to the operator and to staff that might occur suddenly. This is a word frequently used to alert the operator and other persons in order to avoid surprises when using mowers / mulchers.

DANGER: The word “DANGER“ indicates what must not be done, because it implies risk.

THE ADDITIONAL WARNINGS SUCH AS “WARNING” AND “IMPORTANT” REFER TO SPECIAL INSTRUCTIONS RELATED TO THE SAFETY OF TRACTOR PLANT RESIDUE SHREDDER – MULCHER.

SAFETY OF TRACTOR PLANT RESIDUE SHREDDER

WARNING: THIS WARNING DRAWS ATTENTION TO OPERATOR OF POTENTIAL DAMAGES OF MULCHER IF HE FAILS TO COMPLY WITH ANY INSTRUCTIONS.

IMPORTANT: THE READER IS INFORMED ABOUT SOMETHING HE SHOULD KNOW TO PREVENT MINOR FAILURES ON MULCHER, IN CASE HE MISSES IT.

WARNING!

FAILURE TO OBSERVE THE WARNINGS “CAUTION”, “ATTENTION” AND “DANGER” MAY CAUSE SERIOUS BODY INJURIES.

WARRANTY LIMITATIONS

The factory provides warranty in compliance with the Law on Standardization, Regulation on technical standards for agricultural machinery (Official Gazette of SRJ, No. 34/95) and the Regulation on measures and norms of protection and safety at work equipment (Official Gazette of SFRY No. 18/91) for each original part of the mulcher delivered to the customer by the sales network of FPM AGROMEHANIKA AD Boljevac by which it guarantees that, at the time of delivery, each part of the mulcher was new, without defects in material and workmanship; for rotary mulcher it provides one-year warranty from the date of delivery to the end user, provided that the machine is used and serviced according to the recommendations for handling and maintenance stated in this Manual.

EXCEPTIONS:

1. Parts made of wood are not covered by warranty
2. Parts not manufactured by FPM Agromehanika AD Boljevac (tires, plastics, belts, cardan shaft, shaft guards, hydro-cylinder with connecting hoses, etc.). These items are not covered by this warranty but by the warranty of the corresponding producers;
3. Parts that are normally worn during exploitation such as rotors, cutting blades, cutting blade holders, sliders under mulcher sides.
4. The warranty expires in case of misuse, improper or careless use or damage in an accident. The warranty becomes invalid in case of use of non-original parts and the factory is not responsible for damages caused in transport.

THE FACTORY IS NOT RESPONSIBLE FOR THE LOSS OF PROFITS DUE TO FAILURE OF THE MULCHER, OR INJURY OF ANY THIRD PARTY, OR FOR ANY ADDITIONAL COSTS OF WORK ON REMOVAL AND REPLACEMENT OF PARTS

Customer is responsible for and bears the costs of the following:

1. Regular maintenance, such as lubrication, the oil fill, minor adjustments, etc.
2. Transport of the mulcher to the place where the service is provided during the warranty period and back.
3. Travel time of the authorized servicer to the owner of the mulcher and back, or delivery and return of the mulcher from the service workshop after repair.

This warranty does not apply to the mulcher that was changed or modified without our explicit permission or was repaired by someone else, outside of authorized service.

The warranty is linked to strict compliance to the warning:

All instructions in this Manual must be observed and all the guards should be regularly checked and replaced, if necessary.

No warranty is provided for products that are not new.

Persons who only work in our factory are not official representatives of the factory and have no right to take any obligation on its behalf.

No warranty covers equipment for the products broader than the provided one, therefore the factory is not responsible for injuries resulting from such use.

WARNING LABELS

The following warning labels are placed on your mulcher to ensure your safety and the safety of people who work with you. By holding this Manual in your hand, walk around the machine and check these warning labels and instructions in the Manual. The labels must be clearly visible and legible, otherwise replace them with the new ones.

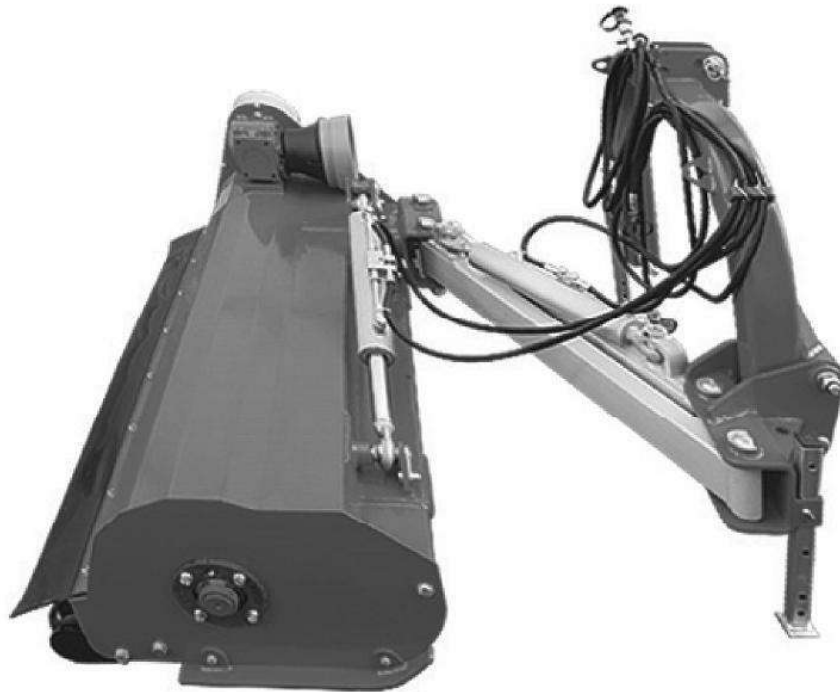

Identification of the mulcher is performed by the identification plate (no. 2) containing the following marks

- The field marked by letter “Z” contains the number of certificate (document) on safety at work
- The field “MASA/WEIGHT” contains the weight of the product;
- The field “GODINA/YEAR” contains the year of production (the last two numbers);
- The field “SERIJA/TYPE” contains batch code and commercial product code;
- The field “№” contains the serial number of the mulcher consisting of nine numbers with the following meaning:
 - 1st number – year of production
 - 2nd and 3rd number – manufacturer’s code
 - the remaining 6 numbers – serial number of product in production

1



2



WARNING LABELS

3

627 14 746	⚠ CAUTION!
BEFORE STARTING THE MACHINE, READ CAREFULLY THE INSTRUCTIONS AND PAY ATTENTION TO THE WARNINGS PROVIDED.	BEFORE STARTING ADJUSTMENT, LUBRICATION OR CLEANING OF THE TOOL, TURN OFF THE TRACTOR, REMOVE THE KEY AND WAIT TILL THE MOVING PARTS STOP MOVING.

4

627 14 747	⚠ CAUTION!
BEFORE STARTING ADJUSTMENT, LUBRICATION OR CLEANING OF THE TOOL, TURN OFF THE TRACTOR, REMOVE THE KEY AND WAIT TILL THE MOVING PARTS STOP MOVING.	BEFORE STARTING THE MACHINE, READ CAREFULLY THE INSTRUCTIONS AND PAY ATTENTION TO THE WARNINGS PROVIDED

5

627 14 748	⚠ ATTENTION!
ROTATING ELEMENTS! Possible bouncing of objects to other objects and persons. Keep away from the machine for your own safety	ROTATING ELEMENTS! POSSIBLE BOUNCING OF OBJECTS TO OTHER OBJECTS AND PERSONS. KEEP AWAY FROM THE MACHINE FOR YOUR OWN SAFETY!

6

627 14 776	⚠ ATTENTION!
ROTATING ELEMENTS! Keep your feet from rotating parts. Turn off the tractor and cardan shaft.	ROTATING ELEMENTS! KEEP YOUR FEET. BE CAREFUL WHEN WORKING WITH THE TOOL. TURN OFF CARDAN SHAFT AND THE TRACTOR.

7

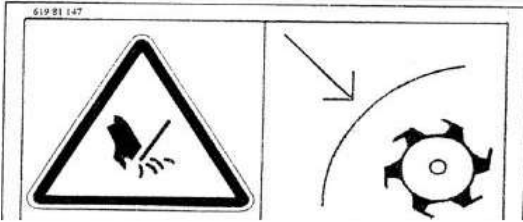

ROTATING ELEMENTS!
Keep your hands. Be careful when lifting and lowering the trailer. Turn off the tractor and cardan shaft.

	! ATTENTION!
ROTATING ELEMENTS! POSSIBLE BOUNCING OF OBJECTS TO OTHER OBJECTS AND PERSONS. KEEP AWAY FROM THE MACHINE!	

8



THE RISK OF FALL
Never transport other persons on the machine during the work or transportation.

	ATTENTION!
THE RISK OF FALL NEVER TRANSPORT OTHER PERSONS ON THE MACHINE DURING THE WORK OR TRANSPORTATION.	

9

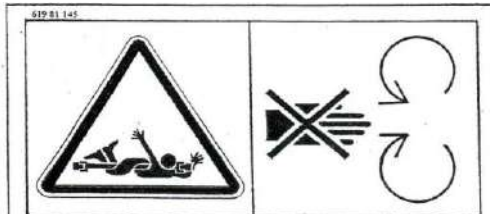

ROTATING ELEMENTS!
When approaching the mulcher at work, take care that the moving parts do not catch parts of your body or clothes. Tie the shaft guard with chains for fixing.

	! ATTENTION!
ROTATING ELEMENTS! WHEN APPROACHING THE MULCHER AT WORK, TAKE CARE THAT THE MOVING PARTS DO NOT CATCH PARTS OF YOUR BODY OR CLOTHES. TIE THE SHAFT GUARD WITH CHAINS FOR FIXING.	

10

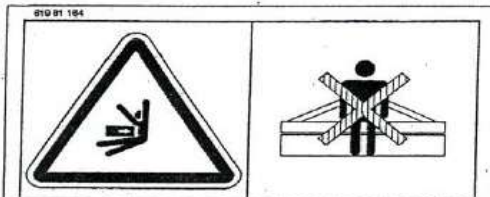

THE RISK OF INJURY
Keep a safe distance from the tool. During operation or transportation.

	! ATTENTION!
RISK OF INJURY DURING TRANSPORTATION. KEEP A SAFE DISTANCE. IN THE ZONE OF WORK WITH THE TOOL!	

ATTENTION:



THIS TRIANGULAR SYMBOL IS USED WHEREVER THERE IS THE NEED FOR YOUR SAFETY, SAFETY OF OTHER PEOPLE, AND TO HAVE YOUR MULCHER PROTECTED FROM RISK. THEREFORE, READ CAREFULLY THE WARNING WHEREVER YOU SEE THESE SIGNS.

INFORMATION FOR PROPER READING OF THE MANUAL

In this manual “left” and “right” is defined in terms of the driving direction.

- A – Front part
- B – Rear part
- C – Left side
- D – Right side (marks are shown in Figure 1)

Metric thread is used during installation. Tighten all screws during installation.

Letters are used for each figure to indicate where to install items.

Carefully read the text to properly install the mulcher

DESCRIPTION OF THE TOOL

SIDE PLANT RESIDUE SHREDDERS – MULCHERS:

- FPM 618 192 / 193 / 194 – working width 1,6 / 1,8 and 2,0 m

are group of tools designed for mechanical shredding of plant residue on all agricultural, public, abandoned or uncultivated areas. They can be used for shredding grass, plant residue, work along the roads, in canals, for shredding of branches in orchards, residues after pruning of vine in vineyards, after harvesting of field crops, etc. This results in improving of the quality and fertility of the soil and decreasing the use of artificial fertilizers.

Constructive solution is quite robust, customized for intensive work and has the possibility of mechanical lateral movement.

Standard plant residue shredder – mulcher is connected to the rear part of the tractor.

For heavy-duty operations it is recommended to use hammer-blades, and for other, less heavy-duty operations, universal Y blades are used for shredding grass and other plant residues.

Double spiral rotor with 45° - with its distribution of working bodies, which is installed in these models consumes much less energy, so that it takes less tractor power, and the load on the vital parts of the shredder is much lower.

Multiplier (for 540°/min) has a built-in one-way coupling.

Three-point linkage for tractors: category I and II and the capacity of lateral movement in relation to the axis of the tractor. Standard equipment includes the following: front security guards (flaps), height adjustable roller, and selection of working bodies – hammer or universal (Y) blade.

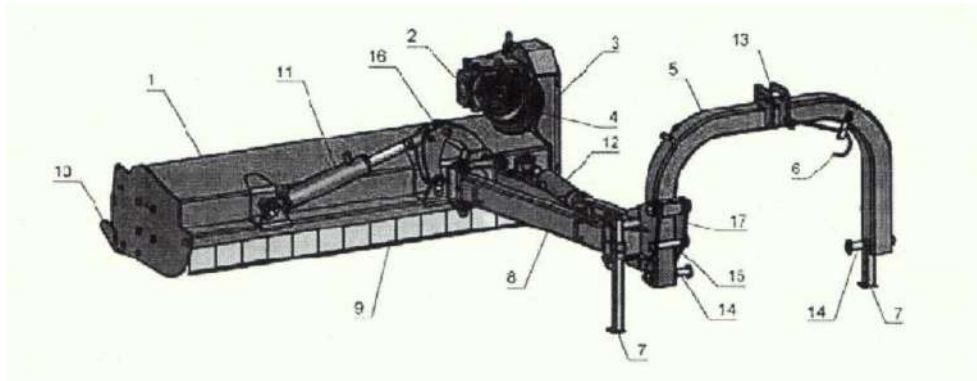

PARTS OF PLANT RESIDUE SHREDDER

1. Mainframe (housing) of mulcher
2. Multiplier
3. Lateral belt transmission
4. Cardan shaft guard
5. Connecting frame of mulcher
6. Cardan shaft holder
7. Supporter

8. Connecting frame bearing
9. Protective flaps
10. Roller
11. Hydro-cylinder of mulcher
12. Hydro-cylinder of arm
13. 3rd connecting point
14. Connecting point
15. Protector
16. Rotary mechanism
17. Connecting frame connection



SAFETY



Most accidents occur during operation, maintenance and transport as a result of failure to comply with basic safety requirements. For operation and maintenance of the mulcher, whether you work alone, with family members or other persons, be sure to read and observe the basic procedures for working with mulcher. In addition, the mulchers are provided with the warning labels that should draw attention to the obligation to observe safety.

- ⚠ The instructions for operation, maintenance and safety at work must be unconditionally observed in order to secure a safe and secure work with mulcher.
- ⚠ Before starting work the operator must be absolutely familiar with the functioning of all parts of mulcher, it might be too late during the work. First of all, learn how to turn off the mulcher quickly and safely in an emergency situation.
- ⚠ Instructions for use and maintenance must be kept for the estimated operating time of the mulcher.
- ⚠ The metal plate must always be legible, visible and clean.
- ⚠ When connecting or disconnecting the mulcher to and from the tractor, always move the supporter to the adequate position (safety).
- ⚠ The tool must be aggregated to a tractor with adequate engine power.
- ⚠ When disconnecting or connecting the mulcher to and from the tractor, be particularly careful, because the area around the lifting levers is a danger zone
- ⚠ Observe the permitted axle load and total weight. Because of the weight, there is a different redistribution of loads on the axles of the wheels.
- ⚠ Due to safety requirements while driving, use a tractor with a cabin. Keep all the glasses closed while working.
- ⚠ Before you start the mulcher, even for a very short distance, always turn and secure it in its transport position. Pay attention to the permitted dimensions when transporting.
- ⚠ Before you start driving on public roads, be sure to secure the mulcher for safe driving and obey the rules of conduct in public transport.
- ⚠ When required by special circumstances, use the light signals to indicate the danger if it is not forbidden by traffic regulations.
- ⚠ Never transport other persons on the other mulcher or tractor during work or transport.
- ⚠ Do not transport mulcher if it is loose and not-secured for safe driving.
- ⚠ Never drive turned-on mulcher.

- ⚠ Never turn on the cardan shaft of the tractor when the mulcher is in the transport position
- ⚠ Never leave the driver's seat while the tractor is in operation mode.
- ⚠ Each time before using the mulcher, make sure that all the parts (nuts, screws, etc.) are adequately tightened; particularly tighten the blades on the rotor.
- ⚠ If the blades on the rotor and the parts that are used to tighten them (bolts, screws, etc.) are worn or damaged, replace them immediately with the original parts manufactured by FPM AGROMEHANIKA AD BOLJEVAC.
- ⚠ Before starting the adjustment, lubrication or cleaning of the mulcher, turn off the engine of the tractor, remove the ignition key, turn off the cardan shaft and pull the parking brake of the tractor.
- ⚠ Wait for the rotary parts to stop moving before you approach the mulcher.
- ⚠ Never wear loose clothing that might be caught by the rotary parts of the mulcher. Clothing should fit to the body. Use protective clothing, goggles, gloves and shoes, particularly when working on rocky soil.
- ⚠ The operator must be absolutely certain that no person or animal is located in the area of working with the mulcher, before he starts the mulcher and starts working. One should always think about the consequences of irresponsible work, because they are irreparable.
- ⚠ Remove foreign objects from the field before you start working.
- ⚠ **IMPORTANT:** By the roads, footpaths, public areas (parks, schools, etc.) and on the rocky soil, work with special care and secure the working conditions in order to avoid the risk of accidents due to bouncing of objects to other objects and persons.
- ⚠ Never work with the machine when reversing.
- ⚠ It is absolutely forbidden to have the mulcher operated by an incompetent person, a person without a driver's license or a person without adequate psycho-physical characteristics.
- ⚠ At the end of the season working with the mulcher, it is necessary that the authorized servicer inspect your mulcher, bring it into proper condition, particularly the blades on the rotor, and to accurately tighten all the parts (screws, nuts, etc.).



THESE WARNINGS MAY NEVER BE NEGLECTED



SAFETY



CONNECTING MULCHER TO TRACTOR

- ⚠ Before each connecting and disconnecting of the mulcher to and from the tractor, lock hydraulic controls to prevent any unintentional lifting or lowering.
- ⚠ When connecting, pay attention to the category of the tractor and the connecting levers of the mulcher - they must be adjusted.
- ⚠ Zone around the connection points is very dangerous. There is a risk of injury when connecting the connecting levers.
- ⚠ When using external commands for hydraulics do not stand between the tractor and the mulcher.
- ⚠ Observe and block the lateral movement of the connecting levers of the tractor during transport.

- ⚠ When driving on public roads with the mulcher in transport position, the tractor hydraulics commands must be blocked against unintentional lowering.
- ⚠ Do not use the mulcher for work on uneven/bumpy terrain.



THESE WARNINGS MAY NEVER BE NEGLECTED



SAFETY



USE OF CARDAN SHAFT

- ⚠ It is allowed to use only the cardan shafts that are delivered with the mulcher or recommended by the manufacturer of the mulcher.
- ⚠ Cardan shaft lining must be installed and be in proper condition and position.
- ⚠ Take care of proper overlapping of tubes in transport and operating position
- ⚠ Connecting and disconnecting of the cardan shaft can be performed only with the turned off output cardan shaft of the tractor, turned off engine and ignition keys pulled out.
- ⚠ The angle at which the cardan shaft operates should be the lowest possible one which ensures a long life of the cardan shaft and the tool.
- ⚠ Always properly install cardan shaft.
- ⚠ With particular attention, tie the cardan shaft guard with the chains that are set for this purpose (the cardan shaft guard must not rotate), be sure to read the instructions provided with the cardan shaft. If the guard is damaged, immediately replace it with the new one.
- ⚠ When not using the mulcher, hook the cardan shaft with the bearing.
- ⚠ If you are not sure of how cardan shaft works, if it is unprotected, or the protection has been used or broken, replace it with the new one having the “CE” mark.
- ⚠ Before turning on the output shaft of the tractor check if the selected speed and direction of rotation is customized to the permissible speed and direction of rotation of the mulcher.
- ⚠ Before turning on the output shaft of the tractor, check that there are no persons or animals in the danger zone of the mulcher.
- ⚠ Do not turn on the output shaft while the tractor engine is turned off.
- ⚠ If the cardan shaft is damaged, fix the damage immediately; it is best to contact the nearest service center. Any unprofessional intervention leads to imbalance of the shaft, which may result in deterioration in performance or damage to the mulcher or the output shaft of the tractor.



THESE WARNINGS MAY NEVER BE NEGLECTED

Specification of technical characteristics

		FPM 618 192	FPM 618 193	FPM 618 194
Width	cm	162	181	200
Tractor power	kW	29 - 52	37 - 59	44 - 66
Tractor power	HP	40 - 70	50 - 80	60 - 90
Tractor output shaft RPM	min ⁻¹	540	540	540
Y-blades	kom.	40	44	48
Hammer blades	kom	20	22	24
Weight	kg	540	575	610
Linkage	kat.	II	II	II



	A	B	C	D	E
160	162	106	70	100	184
180	181	125	70	100	184
200	200	144	70	100	184

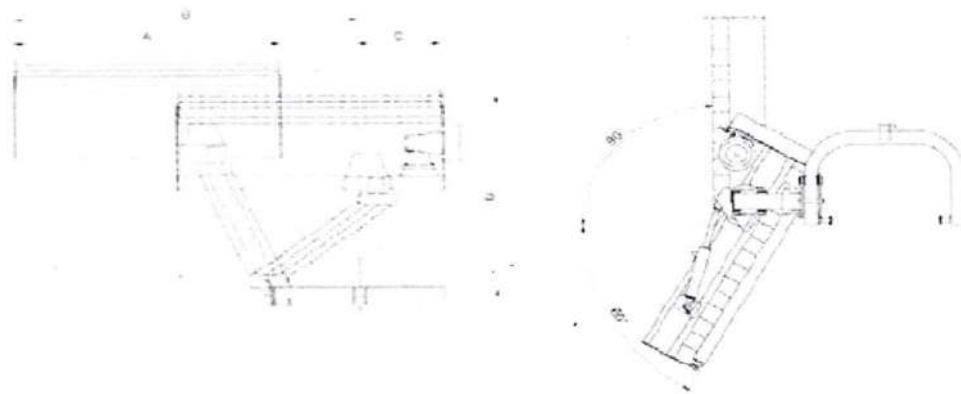

	A	B	C	D
160	162	272	58	184
180	181	291	58	184
200	200	310	58	184

TRANSPORT OF PLANT RESIDUE SHREDDER – MULCHER



DANGER:

If the mulcher is transported on public roads, it is mandatory to secure it for safe driving, and observe the rules of conduct in public transport. The tool must be at least 40 cm above the ground level.

If the mulcher is transported by truck or rail, one should read “SPECIFICATION OF TECHNICAL CHARACTERISTICS” presenting the weights and dimensions.

PROCEDURE OF AGGREGATING ON THE TRACTOR

WORK BEFORE USE



ATTENTION:

Connecting the mulcher on the tractor can be very dangerous operation. Pay special attention and strictly observe the provided instructions.

Do the following:

- Use a tractor whose configuration can meet the needs of plant residue shredder.
- Make sure there are no objects, people or animals in the vicinity of the tool, and that the drive shaft of the tractor is turned off.
- Make sure that the tool is in stable, horizontal position.
- Slowly place the tractor at an angle of 90° relative to the tool, use the hydraulic arm to lower the bottom tractor lever to the height of the connecting points’ axle of the mulcher, and turn off the tractor.

IMPORTANT: If the tractor is in wrong position, it is considerably easier to again move the tractor back and forth rather than trying to personally move the tool to the tractor’s levers.

- Install the cardan shaft, first in the tubed shaft on the tool, and the other end to the output shaft of the tractor. Secure the shaft with the existing protectors in that position.
- When the cardan shaft is maximally extended in operating conditions, the telescopic tubes must be overlapped by at least 1/3 of the length (A on Figure 4).
- When the cardan shaft is maximally retracted there must be a space of 4 cm (B, Figure 4).

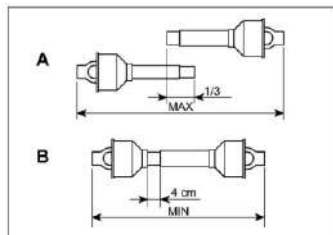

Figure 4

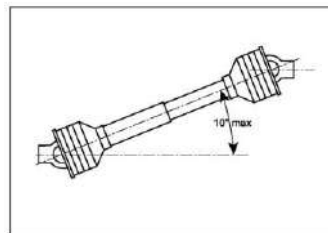

Figure 5

- Hook the bottom left tractor lever to the left sleeve of the tool, and secure it with the existing protectors.
- Hook the bottom right tractor lever to the right sleeve of the tool, and secure it with the existing protectors.
- Fix the left and right tractor lever with proper chains to make them parallel with the tractor. This is done to limit the laterally swinging of the tool from 5 to 10 cm.
- Then, from the tractor seat, with the hydraulics control handle in the lower position on the quadrant, slowly move the tractor forward or backward until it has access to fastening the front end of the upper tractor lever (toplink) for the tractor and secure in this position with the existing protectors.
- When you hooked the tool to the tractor, it is necessary to bring the upper part of the tool into the horizontal position, i.e. to make it parallel with the ground. This is done by shortening or lengthening of the upper tractor lever (toplink).

IMPORTANT: The order of hooking of the tool to tractor should always be the same:

- a) Left bottom tractor lever
- b) Right bottom tractor lever
- c) Upper tractor lever

IMPORTANT: After you finish bringing the mulcher in the horizontal position, you can access other adjustments required for the normal functioning of the mulcher.

- By using hydraulics, carefully lift the mulcher so that the angle of breaking of the cardan shaft is not too large (never larger than 10°, Figure 5). When you lifted the tool to the highest position in this way, check the following:

- a) whether the cardan shaft rotates freely and the joints do not get stuck somewhere
- b) whether the cardan shaft is not overstretched
- c) check whether the shaft guard can rotate freely
- d) secure the shaft guards, with the existing chains from the cardan shaft.

IMPORTANT: It is very important that the guards at the output shaft of the tractor and on the connecting shaft of the tool overlap at least 5 cm. If some guards are not in good condition, they must be immediately replaced by the new ones.



DANGER:

Never modify or adapt the cardan shaft. Contact the nearest service center if necessary.

WORKING WITH THE PLANT RESIDUE SHREDDER - MULCHER

OPERATING POSITION



DANGER:

The operator must sit in the driver's seat because only from there he can properly operate the tool.

Before leaving the driver's seat, the operator must stop the work of the tool, pull the parking brake and turn off the tractor engine.

DURING OPERATION

After the proper connection of the tool to the tractor, taking a driver's seat and starting the tractor, do the following:

- By using hydraulics, lift the tool to 10 - 20 cm from the ground
- Let the tractor work with low engine speed and turn on the output shaft of the tractor
- Engage a gear to move forward, and increase the engine speed
- Gradually (slowly) lower the tool until it touches the ground. By doing this, you enable the tool to adapt to the relief of the ground.



DANGER:

Do not accelerate too much when the tool is running

- Drive the tool for a while and then check if the quality of shredding is satisfactory
- The height of shredding can be regulated by adjusting the roller

Factors to be taken into account in order to select the appropriate shredding:

- Plant height
- quantity and size of all branches on the ground
- tractor speed
- optimal shredding height

Good shredding is achieved at low speed of the tractor and high speed of the rotor with blades.

**CAUTION:**

To avoid damaging the tool or breaking of the blades, the speed of the tractor during operation should be limited to 6 -8 km/h. When the tool is in operation, do not change direction and do not make sharp turns. Never drive backwards when the tool is on the ground!!!

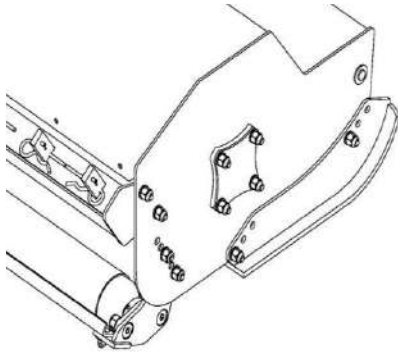
ADJUSTING THE PLANT RESIDUE SHREDDING HEIGHT**DANGER:**

Adjusting the shredding height is a dangerous operation. Wear protective gloves and use the appropriate tools and accessories.

When adjusting the shredding height, do the following:

- Park the tractor on a flat area and use the hydraulics to lift the tool from the ground.
- Place two stronger supports on sides under the tool to secure it against the fall. - Lower the tool to the supports, turn off the tractor engine and pull the parking brake.

The plant residue shredding height is determined by the position of the turning plate to which the roller bearing of the tool is fastened (see

Figure 6). To change the position of the roller, loosen the screws (Figure 6) on both sides of the side panels, remove the screws on one side, move the roller up or down depending on the required shredding height. Put the screws back and repeat the same procedure on the other side. Then tighten the screws.

Greater shredding height is achieved by lower roller position and vice versa, the lower one with the higher roller position, because the tool is closer or farther away from the ground.

When you move the roller in a position closer to the ground downwards, you need to set up the third connection point (toplink) to make the tool parallel to the ground.

HELPFUL TIPS FOR YOU

Here are some helpful tips on how to solve some problems that might occur during work.

PLANT RESIDUE IS TOO SHREDED

- slightly lift the blades from the ground, adjust the height using the roller (cutting blades must not touch the ground)
- Increase the speed of the tractor

PLANT RESIDUE IS NOT SHREDED ENOUGH

- slightly lower the blades to the ground, adjust the height using the roller (cutting blades must not touch the ground)
- reduce the speed of the tractor
- do not work if the soil is too wet

ROTOR GETS STUCK

- the soil is too wet
- lift the tool from the ground
- reduce the speed of the tractor
- do not work if the grass is too high

Remove all plant mass that is stuck on the sides of the rotor to avoid overheating of the bearings.

THE TOOL BOUNCES AND VIBRATES

- stuck foreign objects (the stump, wood, stone) between the blades
- the blades are improperly installed
- the blades are worn or broken
- during work the rotor was damaged by the impact of foreign bodies to its central part

OTHER DEFECTS

The tool does not shred the mass along its entire length - blades are of unequal length. Use the shortest blade as a pattern and grind all the blades to the left and right to the same length

WORK ON SLOPING TERRAIN

When working with the tool, move in the direction of the slope.

OPERATING ELEMENTS - CUTTING BLADES

Check the condition of the working elements - cutting blades the shredder is equipped with, and see whether they are worn. If the blades bend or break during the work, you should immediately replace them with the new ones.



DANGER:

Replacing the cutting blades is dangerous operation, be careful

When replacing cutting blades, do the following:

- Park the tractor with the tool on the flat area, then use the hydraulics to lift the tool from the ground.
 - Place two strong supporters at both ends of the tool
 - Lower the tool to the supporters, turn off the tractor and pull the parking brake

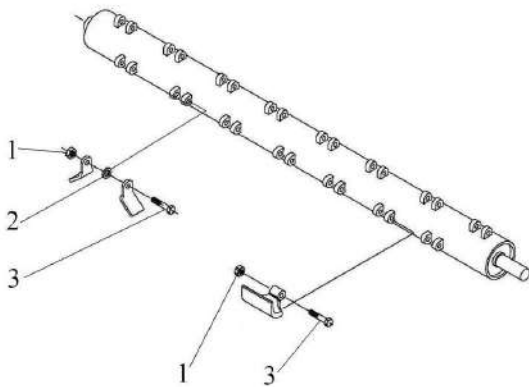

One pair of the blades must be fitted, opposite each other, to keep the “balance” of the rotor

When replacing the **worn or broken blades**, do the following:

- Remove the nut (pos. 1, Figure 8) from the screw that tightens the worn blades. Observe well the position of all parts during the stage of replacement, in particular of the distance sleeve (pos. 3, Figure 8). Install the new blades and other part at the same place, in the same position.
- If the screws (pos. 2, Figure 8) and nuts are damaged, be sure to replace them

Figure 8



DANGER:

If the cutting blades get stuck, it is strictly prohibited to attempt to clean the tool while at work. First, turn off the output shaft drive, then turn off the tractor and pull the parking brake. Wait until the moving parts stop, and then start cleaning the tool. Be careful!

STOPPING THE TOOL

After completion of work the operator must:

- turn off the output shaft drive

- by releasing the hydraulics, lower the tool to the ground
- turn off the tractor engine and pull the parking brake
- make sure that all parts of the tools are motionless

Only after checking the above mentioned operations the operator can leave the driver's seat

PARKING OF THE TOOL

- After completion of work you must park the tool on the flat area
- Stop the tractor engine and pull the parking brake
- When the tractor engine is turned off and all moving parts on the tool are in standby mode, remove the cardan from the tractor output shaft
- Unhook the tool from the tractor.

ATTENTION:



The place where the tool is parked must be:

- Dry
- Sheltered from bad weather conditions
- Protected or locked to prevent access by children or unauthorized persons



CAUTION:

If you do not use the tool for a long period of time, lubricate all parts that are subject to wear and tear, lift the tool on a wooden stand located under the canopy or in a special dry room and cover it with plastic foil.

If you have carefully performed all the activities, then the tool is mobile and ready when there is the need to use it again.

MAINTENANCE

REGULAR MAINTENANCE

Remember that lower maintenance costs and a longer life span of the tool depend on the constant observance of the provided instructions.



ATTENTION:

Before you start any operation, make sure the tool is parked on the flat area.

Secure the tool against moving by placing supporters under wheels.

Maintain, adjust and prepare the tool for work only when cardan shaft is removed from the tool.

The frequency of servicing suggested in this Manual, refer to the normal conditions of use. Servicing must be carried out more frequently in severe conditions of use.



CAUTION:

Before you inject grease, you need to use a dry cloth to wipe around the grease box and the box itself to avoid that the mud and dust mixed with grease reduce quality of greasing.

Do the greasing with maximum caution, because injecting large quantities of grease under pressure can damage the protection of bearings. Grease all the places designed for greasing.



DANGER:

Keep all the lubricants out of reach of the children!

Read carefully all warnings on the packages of greases and lubricants. After the work on greasing, the operator - servicer must thoroughly clean parts of the body of the grease and lubricants.

The grease/lubricant that was used must be disposed in the prescribed manner, in compliance with the Law on Environmental Protection.

REPLACEMENT OF V-BELT



V-belts are properly tightened if the deflection is max. 10 mm to prevent excessive slipping.

Inadequately tightened belts are the cause of poor performance of the mulcher and early damage and tear of belts.

When replacing belts, or check their tightness, do the following:

- Unscrew the nuts and remove the protective coating of the V-belts
- Loosen the screw that holds the housing of the drive sheave
- Tighten the adjustment screw to the extent necessary to provide the necessary tension of the belts
- Tighten control nut of the adjustment screw
- Tighten all screws that hold the housing of the drive sheave
- Put the protective layer back to its place.

All parts of the transmission from reductor to the drive sheave must be in line when tightening of belts. Loosen the screws on the reductor board, lift or lower the reductor, so that the transmission shaft is parallel to the top plate of the tool, then tighten the screws.

Make sure whether the sheaves are in the same line when tightening or changing the belts. To check, use a metal ruler that must be placed on both sheaves' area. The edge of the ruler must adhere to all four points.



WARNING:

IT IS NECESSARY AND IMPORTANT TO CHECK THE BELT TIGHTNESS AND TO TIGHTEN THEM PROPERLY. IT IS VERY IMPORTANT TO DO THAT AFTER 0.5 HOURS OF USAGE OF THE TOOL. WHEN REPLACING THE WORN BELTS, REPLACE THE SET OF BELTS, REGARDLESS OF THE STATE OF ONE BELT COMPARED TO THE OTHER.

LUBRICATION

It is very important to properly lubricate any tool, both the transmission and all parts that slide one inside the other, in order to meet the strict requirements for working in the most difficult conditions, which is of vital importance for the long life and functionality of the tools.

Therefore, lubrication must be performed regularly - at certain time intervals. The time interval for the lubrication provided in this Manual relates to the tool that is used in normal conditions.

If the tool works in hard working conditions, then lubrication must be performed at shorter intervals.

RECOMMENDED LUBRICANTS

For lubrication of the gear in the multiplier it is recommended to use the hypoid oil SAE 85W-140, to achieve the quality level of the US military specification MIL-L-2105C and API Service Classification GL-5 or JUS B.H3.303 type "MP -5".

RECOMMENDED GREASE

- For the lubrication of all the places where the greasing boxes are located, use a calcium grease with an additive that increases adhesion to metal surfaces that meets JUS B.H3.634 VM-2 specifications NLGI 2.

FOR OIL CHANGE, USE:

Name of manufacturer	Oil code
Refinery Beograd	HIPOL - B
"FAM" Krusevac	MULTI HIPO
"MODRIČA" Modrica	HIPOIDNO ULJE - B
"INA" Zagreb	HIPENOL GTL
"SHELL"	SPIRAX - HD
"MOBIL"	MOBILUBE - HD
"VALVOLINE"	"VALVOLINE" X-18
"ESSO"	ESSO GEAR OIL GX
"CASTROL"	CASTROL EPX

FOR GREASE CHANGE, USE:

Name of manufacturer	Grease code
Refinery Beograd	LUMA - 2
"FAM" Krusevac	FOR - 2
"MODRIČA" Modrica	LITMA - 2
"INA" Zagreb	LIS - 2
"SHELL"	ALVANIJA R-2
"MOBIL"	MOBILUX 2
"VALVOLINE"	GREASE LB1-2

SERVICE ADJUSTMENTS - AFTER THE FIRST 8 h OF WORK

Check each tool after the first 8 hours of work. The check procedure is as follows:

- Detailed check of the basic condition of the tool.
- Check of wear and damage of the cutting blades; make sure to tighten all screws and bolts on the rotor and the blades.
- Use the necessary torque to tighten all screws and bolts.

SERVICE ADJUSTMENTS - AFTER EACH 20 h OF WORK

- Check and tighten all screws and bolts on the rotor and the blades by the necessary torque.
- Lubricate all parts of the cardan shaft, roller bearings and all screws on the panel for adjustment of the roller height.

SERVICE ADJUSTMENTS - AFTER EACH 100 h OF WORK

Check the oil level in the multiplier housing. If necessary, add oil through the cap on top of the housing (Figure 15, Pos. 1).

SERVICE ADJUSTMENTS - AFTER EACH 500 h OF WORK

- Change the oil in the multiplier housing after every 500 hours of operation or at least once a year (Figure 14, Pos. 1).
- It is best to discharge the oil immediately after finishing work with the tool, since the oil is still warm, and the residue in it has not settled yet.

STORAGE – KEEPING OF THE PLANT RESIDUE SHREDDER

- If you do not use the mulcher for a longer period of time, thoroughly clean and wash all the parts that were in touch with the plant debris from the stuck earth and plant debris; do not forget the inner side of the tin chassis and the trailer.
- After cleaning wash the whole tool thoroughly.
- Drain oil from the reductor and fill it with the clean oil to the appropriate level. (Dispose the waste oil and observe the Law on the Environmental Protection)
- All excess oil must be removed carefully with a dry cloth.
- Tighten all screws and nuts on the tool.
- Clean the rusty surfaces and bare points and cover them with protective paint.
- Lift the tool on a wooden stand and place it under a canopy or in a special dry room. If you carefully completed the previous operations, your mulcher is mobile and ready for use in the next working season.



FPM AGROMEHANIKA DOO
Djordja Simeonovica 25
19370 Boljevac – Serbia

DECLARATION OF CONFORMITY 2006/42/EC

We,

FPM Agromehanika DOO,
Djordja Simeonovica 25, 19370, Boljevac, Serbia

hereby declare, as manufacturers within our responsibility that the product

Type: **Side plant residue shredder – MULCHER
(with hydraulic arm)**

Model: **FPM 618 192 – working width 1,6 m
FPM 618 193 – working width 1,8 m
FPM 618 194 – working width 2,0 m**

Year of production: **2016**

is in compliance with all the relevant requirements defined by **European Directive 2006/42/EC (for machines)**.

The product complies with the following standards:

- SRPS EN ISO 12100:2014
- SRPS EN ISO 13857:2010
- SRPS EN ISO 4254-1:2013
- SRPS EN ISO 4254-5:2011
- SRPS EN ISO 4254-12:2013
- EN 1553:2000
- SRPS ISO 11684:1999
- SRPS EN ISO 11201:2014

In Boljevac,
12.05.2016.

Signature of authorized person
DIRECTOR GENERAL
Branislav Rajic, BA in Mechanical Engineering

LIST OF SPARE PARTS
- Instructions for ordering spare parts –

For ordering spare parts or components please contact the Sales Department - spare parts.

The existing images on the following pages present the mechanical parts that are numbered.

The text by each image provides the following information: number of the machine part, its identification number, the quantity within the plant residue shredder and, where applicable, dimension or standard. Pay attention to additional markings on the pages.

To avoid misunderstandings and errors in delivery, when ordering spare parts, please, state the following:

- **Code and number of the mulcher (batch, №)**
- **Number and name of spare part (identify in this list)**
- **Quantity of the required spare parts**
- **Preferred delivery method (regular post, post express, etc.)**
- **Full address of the orderer (with zip code)**

Your mulcher contains the plate (as presented on the image) with the imprinted batch and serial number.

Warranty cases and other issues cannot be solved without information about the batch and serial number.



FIGURE 1

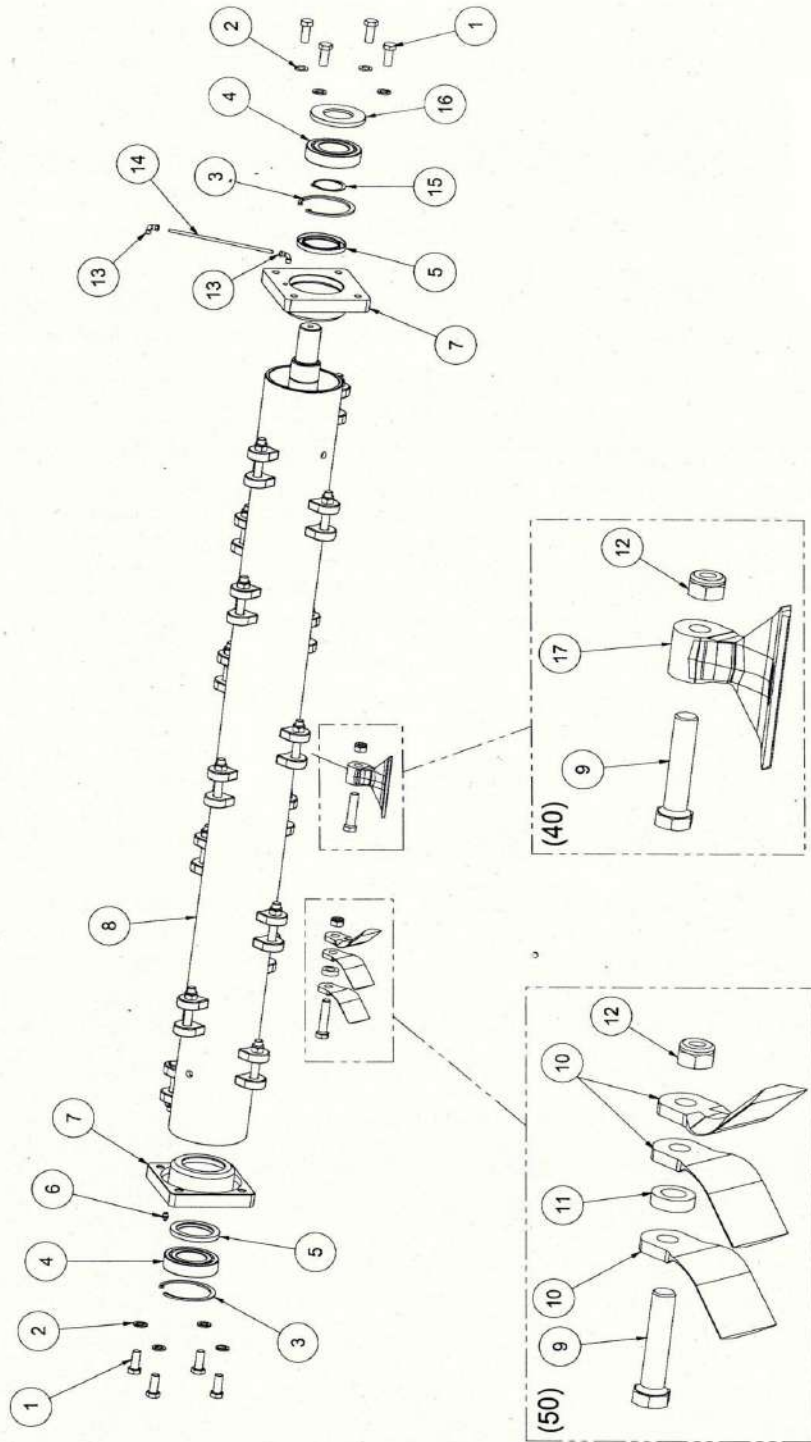

FIGURE 1

Red. br.	Šifra	Količina
1	0019048	8
2	0002367	8
3	0002073	2
4	0018063	2
5	8066201	2
6	0001065	1
7	T1200037	2
8		1
	T0716290	VER 160
	T0718290	VER 180
	T0720290	VER 200
9	8066536	VER 160
		VER 180
		VER 200
10	0058115	VER 160
		VER 180
		VER 200
11	0058118	VER 160
		VER 180
		VER 200
12	0020105	VER 160
		VER 180
		VER 200
13	8064928	2
14	3178795	1
15	0018078	1
16	8066200	1
17	8300045	VER 160
		VER 180
		VER 200

FIGURE 2

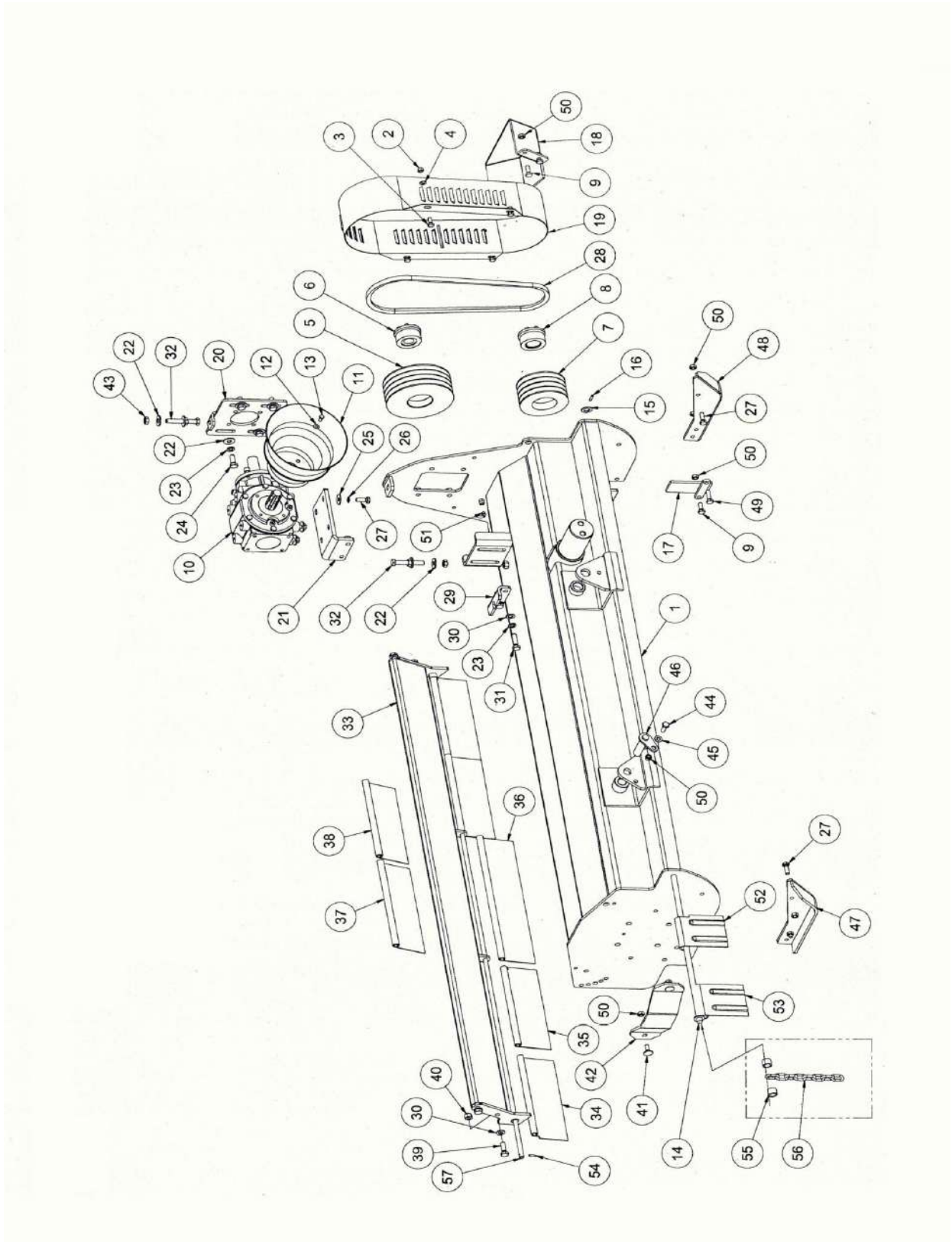

FIGURE 2

1	T1216080	1			
	T1218080				
	T1220080				
2	0030156	4			
3	0033176	4			
4	0002034	4			
5	8066221	1			
6	8066170	1			
7	0058162	1			
8	0058161	1			
9	0015255	5			
10	8066195	1			
11	8066163	1			
12	0015230	4			
13	0015012	4			
14		1			
	T0415091		VER 160		
	0256575		VER 180		
	T0420091		VER 200		
15	0050049	1			
16	0015057	1			
17	T1200066	1			
18	T1200061	1			
19	0056561	1			
20	T1200057	1			
21	T1200088	1			
22	0056807	8			
23	0001020	6			
24	0001526	4			
25	0076106	4			
26	0001077	4			
27	0007255	7			
28	8066248	4			
29	T1200058	1			
30	0091435	6			
31	0029317	2			
32	8066344	2			
33		1			
	T1216076		VER 160		
	T1218076		VER 180		
	T1220076		VER 200		
34	T1200074	2			
			VER 160		
			VER 180		
			VER 200		
35	T1200075	2			
			VER 160		
			VER 180		
			VER 200		
			VER 160		
			VER 180		
			VER 200		
36	T1200092		VER 180		
			VER 200		
			VER 160		
			VER 180		
			VER 200		
37	T1200093		VER 160		
			VER 180		
			VER 200		
38	T1200078		VER 160		
			VER 180		
			VER 200		
39	0074232	4			
40	0030358	4			
41	0051073	2			
42	3177462A	1			
43	0001177	4			
44	0002450	1			
45	0002265	1			
46	T0700341	1			
47	T1200062	1			
48	T1200063	1			
49	0027236	1			
50	0030064	12			
51	0001065	1			
52	T0100055	2			
			VER 160		
			VER 180		
			VER 200		
53	T0100039		VER 160	10	
			VER 180	12	
			VER 200	13	
54	8064817	1			
55	5200798		VER 160	60	
			VER 180	65	
			VER 200	70	
56	3179453		VER 160	60	
			VER 180	65	
			VER 200	70	
57			VER 160	1	
	T1216073		VER 160		
	T1218073		VER 180		
	T1220073		VER 200		

FIGURE 3

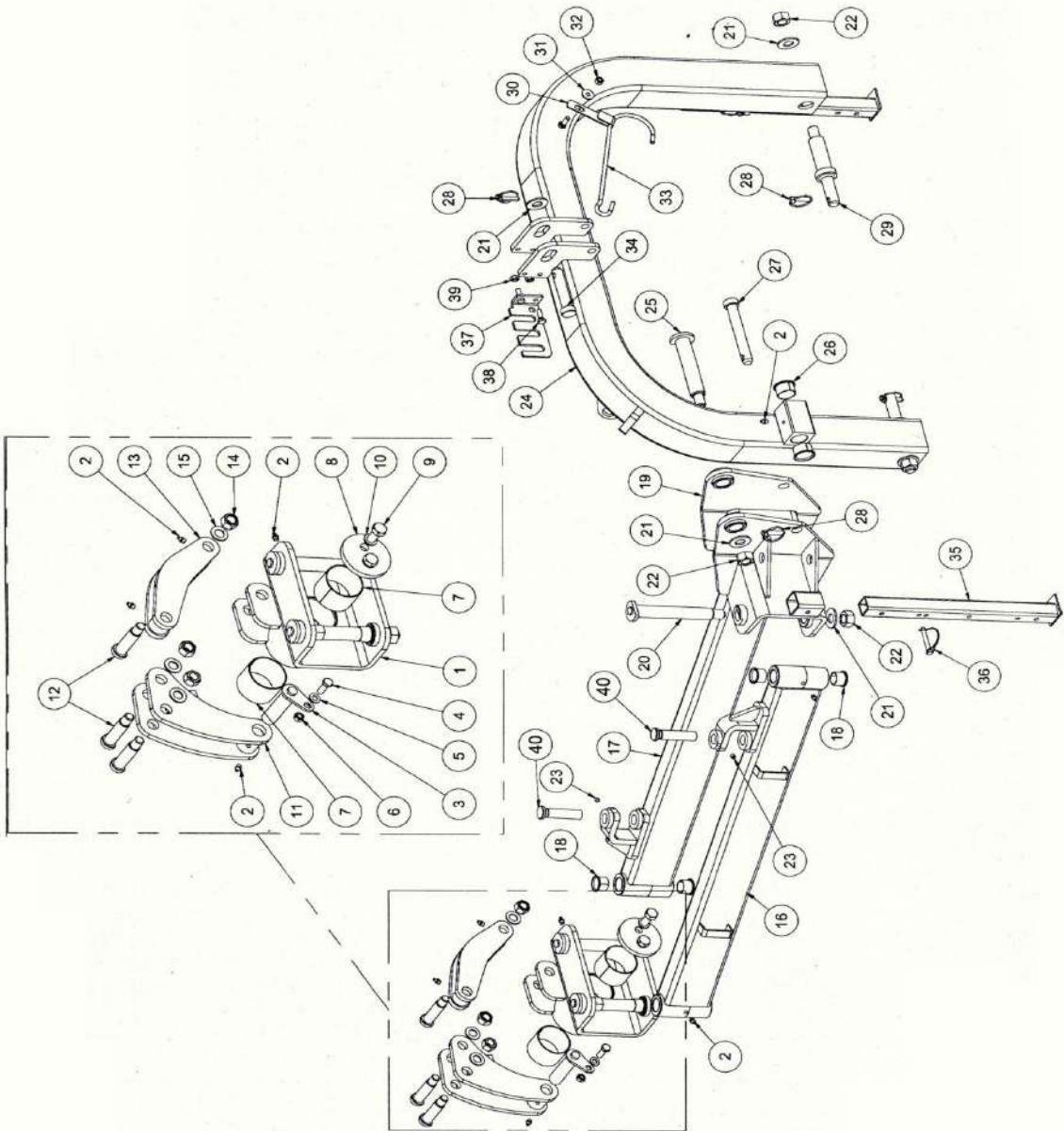

FIGURE 3

1	T0700331	1
2	0001065	9
3	T0700339	1
4	0002450	1
5	0002265	1
6	0030064	1
7	8066222	2
8	T0700332	1
9	0055045	2
10	0003366	2
11	T0700202	1
12	T0700336	3
13	T0700334	1
14	0092279	3
15	0046555	3
16	T0700303	1
17	T0700304	1
18	8066223	8
19	T0700313	1
20	T0700316	4
21	0002298	8
22	8065123	7
23	8064842	2
24	T0700324	1
25	T0700319	1
26	8066224	2
27	E0300099	1
28	0018266	4
29	T0700321	2
30	0060086	1
31	0030157	1
32	0030156	1
33	0060085	1
34	A0700040	1
35	5500445	2
36	0042255	2
37	T0700325	1
38	0001278	2
39	0030156	2
40	T0700380	2

FIGURE 4

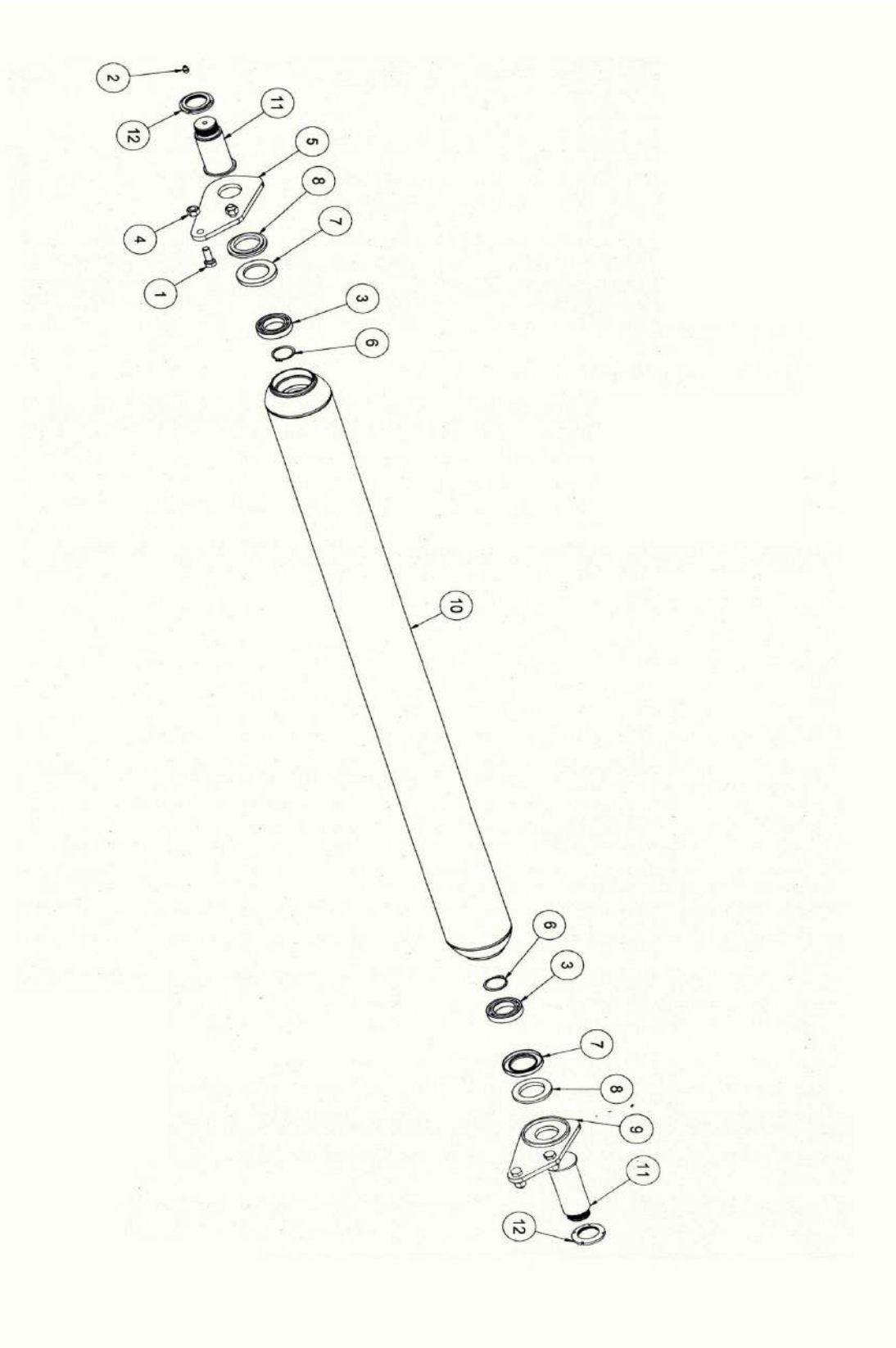

FIGURE 4

1	0074232	4
2	0001065	2
3	0012149	2
4	0030358	4
5	T1200136	1
6	0001154	2
7	0001155	2
8	T1200141	2
9	T1200137	1
10	RULLO	1
	T1216132	VER 160
	T1218132	VER 180
	T1220132	VER 200
11	T1200140	2
12	8066511	2

FIGURE 5

1	T0700294	1
2	T0700305	2
3	T0700293	1
4	0041871	4
5	0036532	4
6	0041870	4
7	0041866	8
8	8064399	4
9	8066181	2
10	8066183	1
11	8066184	1
12	9000020	4



The machine meets the relevant safety requirements of European directives for machines.



OPERATORS SHOULD OBEY ALL APPLICABLE REGULATIONS ON SAFETY AND HEALTH PROTECTION AND REGULATIONS ON ROAD TRAFFIC.

FOR YOUR OWN SAFETY, USE ONLY ORIGINAL PARTS MANUFACTURED BY FPM AGROMEHANIKA AD - BOLJEVAC

MANUFACTURER IS NOT RESPONSIBLE FOR THE CONSEQUENCES OF IMPROPER USE OR NON-COMPLIANCE WITH THE RECOMMENDATIONS PROVIDED IN THIS INSTRUCTIONS MANUAL.



**FOR YOUR OWN SAFETY AND TO GET ALL
THE BEST FROM YOUR PLANT RESIDUE
SHREDDER, USE ONLY ORIGINAL PARTS
MANUFACTURED BY FPM AGROMEHANIKA
AD BOLJEVAC**

FPM AGROMEHANIKA AD

19370 Boljevac, Djordja Simeonovica No. 25

TEL.	Sales department:	+381 (0)30 463 455; 463 356
	Service Department:	+381 (0)30 463 619
	Export-import department:	+381 (0)30 463 531
FAX:		+381 (0)30 463 405